

**SERAC® LH30 / LH50 / LH100**  
with high-quality bearing system for high axial loads

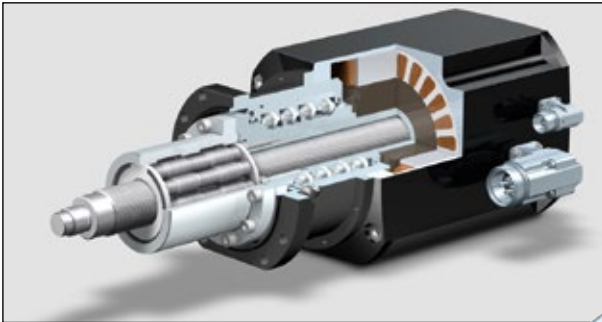

SERAC® LH100 without anti-rotate unit

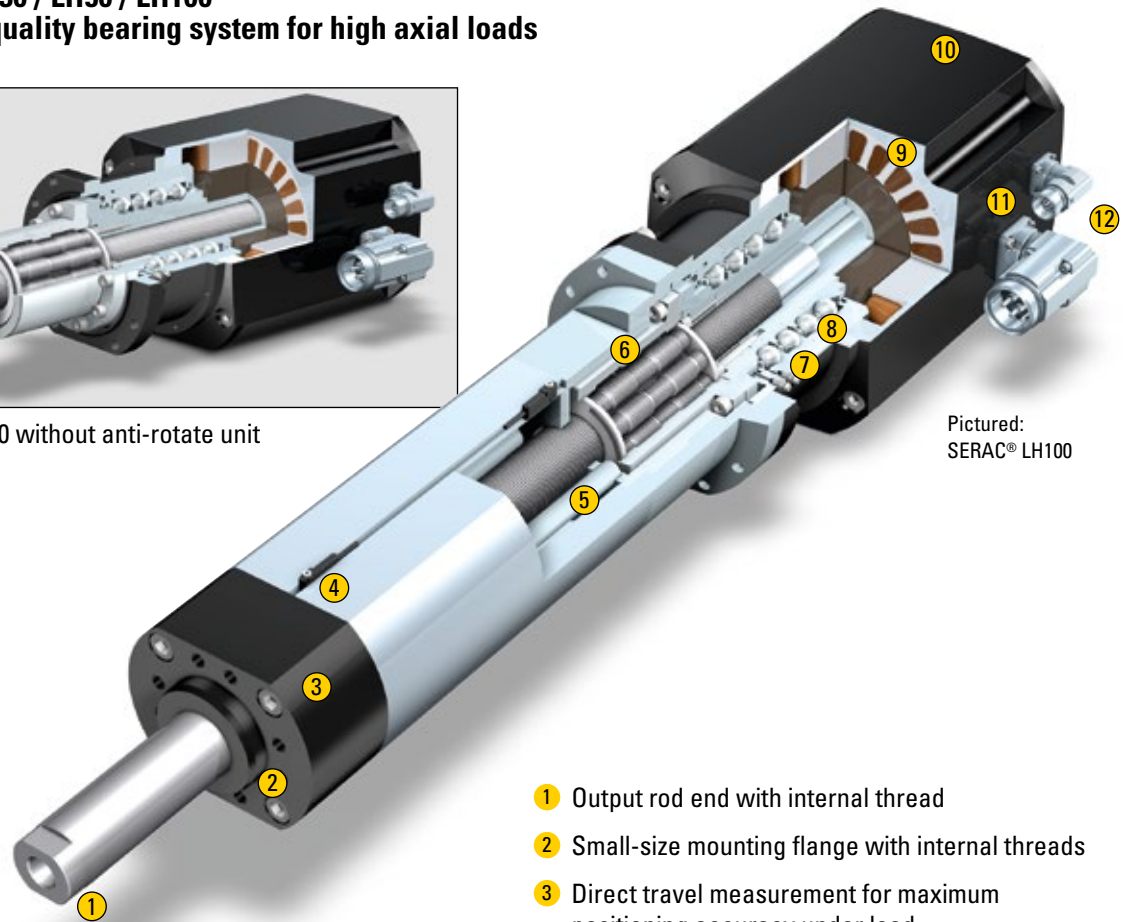

Pictured:  
SERAC® LH100

- 1 Output rod end with internal thread
- 2 Small-size mounting flange with internal threads
- 3 Direct travel measurement for maximum positioning accuracy under load
- 4 Optional safety limit switches
- 5 Anti-rotation device
- 6 ASCA servo screw with directly driven screw nut
- 7 Lubricating nipple for screw and bearing system
- 8 High quality bearing system
- 9 Hollow shaft torque motor with low cogging torque
- 10 Motor encoder (resolver or Hiperface)
- 11 Holding brake
- 12 Electrical connections (power and encoder connectors)